



PERITUS
Racking Solutions

Since **1977**



Pallet Racking Solutions

- Back to Back Pallet Racking
- Drive-in Pallet Racking
- Narrow Aisle Pallet Racking
- Double Deep Pallet Racking
- Silo Pallet Racking
- Pallet Flow Racking
- Mobile Pallet Racking
- Pallet Shuttle Racking
- AS/RS Pallet Racking

Light Duty Shelving Systems

- Sliding Shelving System
- Middle Shelving System
- Rax Type Shelving System
- Hanger Type Shelving System

Other Racking Solutions

- Mezzanine Racking System
- Cantilever Racking System



The story started at 1977 as **PEKTAŞ** was identified as one of the first manufacturing companies for racking solutions in Türkiye.

Pektaş is now one of the leading companies in the region specialized in designing, manufacturing and installation of metal racking, automated warehouse and storage solutions.

By 2024 with its passionate and consistent growth strategy, and after merging all Organizational & Manufacturing Experiences, Pektaş has involved to the name “ **PERITUS** ” Brand as all-in one provider of technologies and storage solutions, with the best quality, innovative and sustainable technologies for its valuable partners in the Global markets.

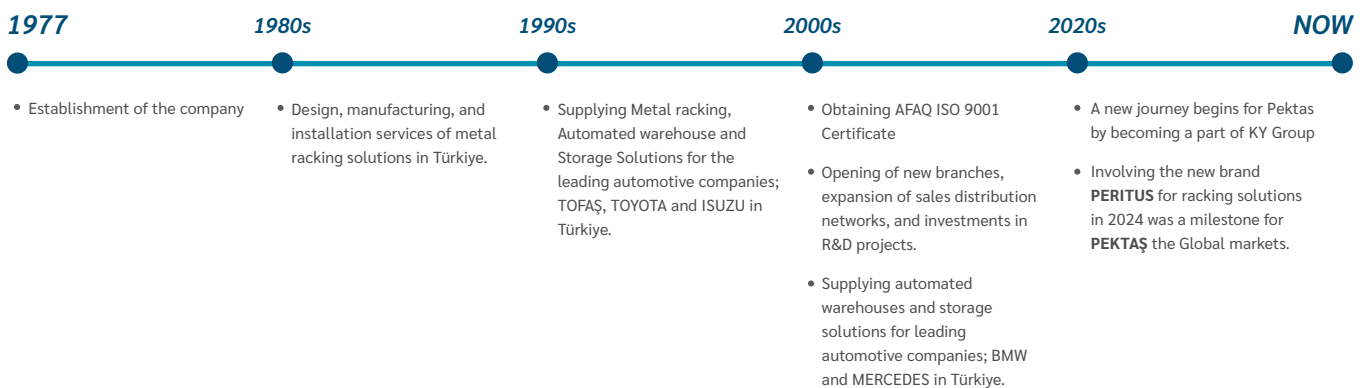

PERITUS



Pallet Racking Solutions

Back to Back Pallet Racking



The Back to Back Racking System is suitable for stacking standard and special pallets. It can adapt to product diversity and variable product weights. Each pallet is stored in an accessible condition independently of each other. Especially since it provides direct access to the products, it is the most frequently used racking system in all sectors with a large product variety.

Back to Back Racking Systems have a strong and unbending structure, so it protects the stored product from crush-like damage.

- › Flexibility in height and depth is available.
- › It provides direct access to all materials.
- › It has the ability to add and remove modules. There are rich accessory options.
- › Adjustable floor height offers easy assembly and quick installation.
- › Suitable for all types of forklifts.

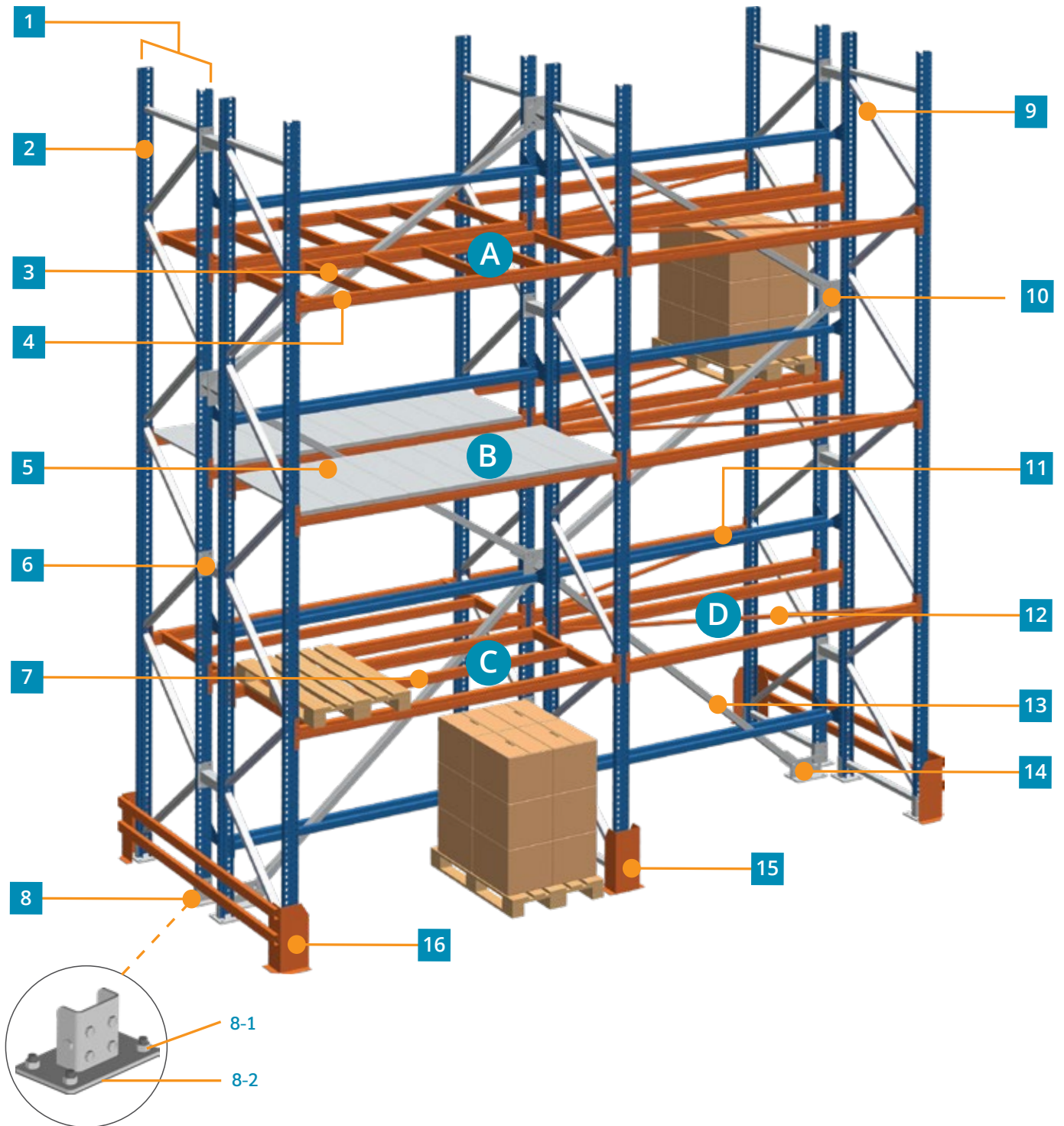

- 1- Frame Set
- 2- Upright
- 3- Pallet Supports
- 4- Beam
- 5- Shelf
- 6- Row Spacer
- 7- "H" Type Pallet Support

- 8- Base Frame Footplate
- 8-1: Anchor Bolt
- 8-2: Leveling Shims
- 9- Frame Diagonal
- 10- Cross Brace Profile Connector
- 11- Pallet Stopper

- 12- Horizontal Cross Brace Profile
- 13- Cross Brace Profile
- 14- Cross Brace Profile Base Connector
- 15- Upright Protector – U Type
- 16 - Barrier Type Protection

Loading Options:

- A- On Pallet Supporter
- B- On Shelf
- C- On Pallet Supporter (H Type)
- D- On Beam

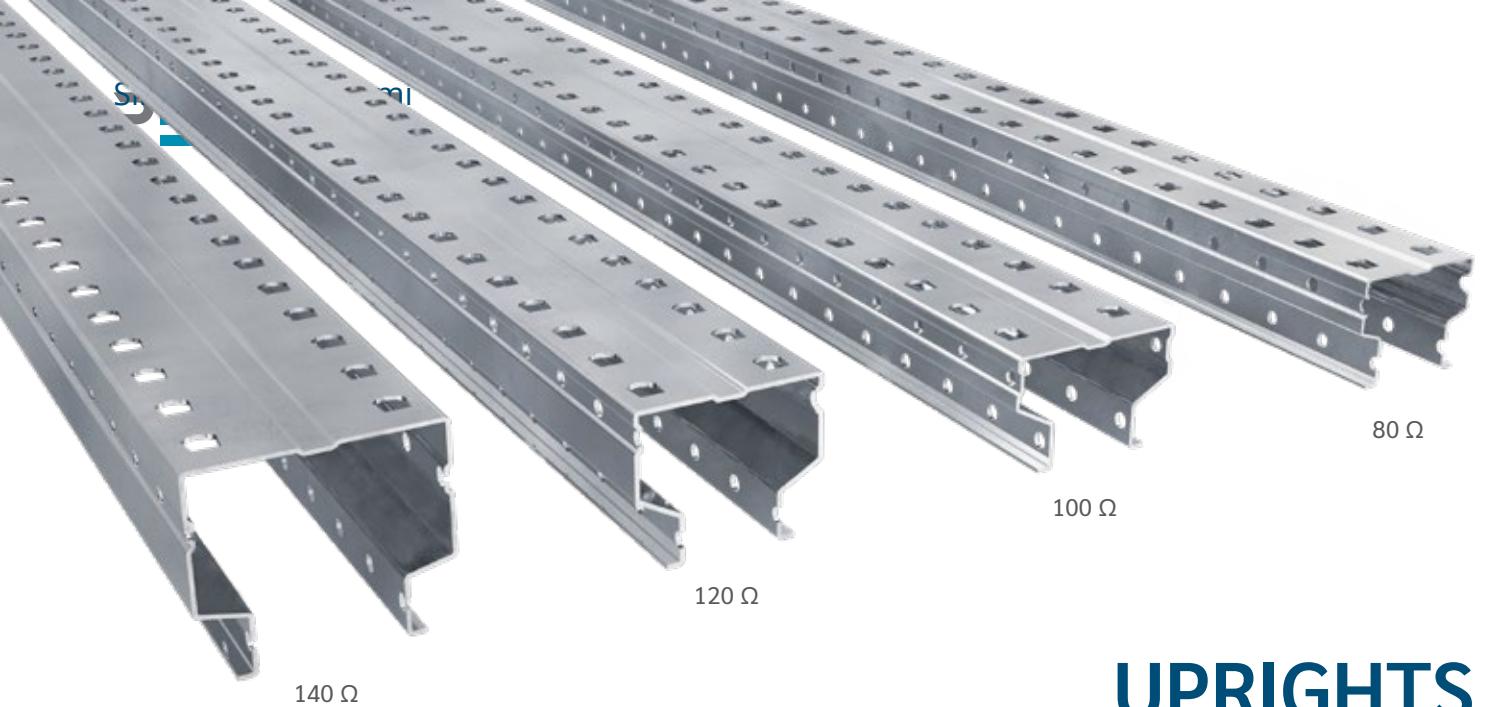

UPRIGHTS

Matches YOUR
Warehouse Needs

45+ Years of Experience

Manufacturing Storage Solutions at the Highest Standards

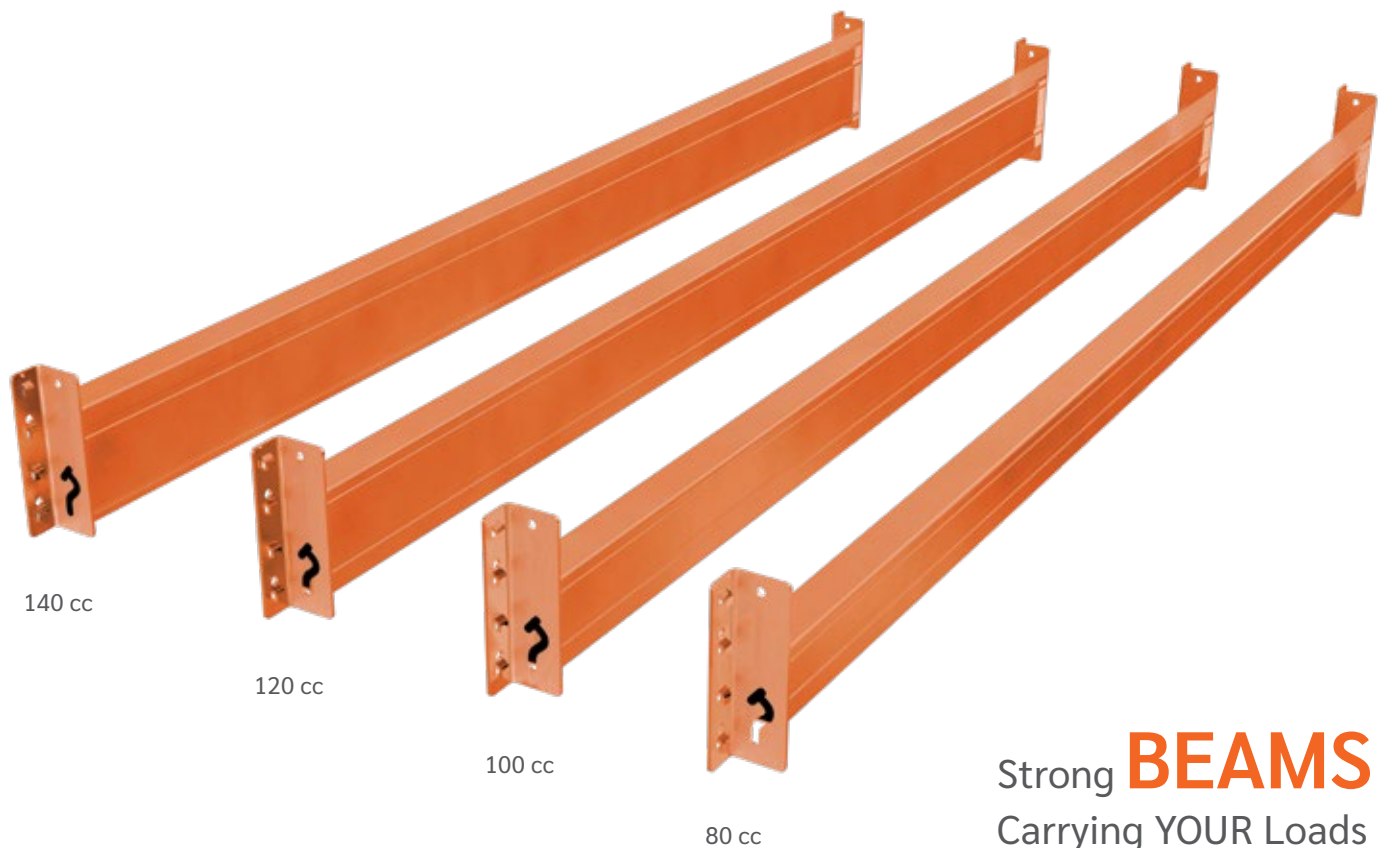

Strong **BEAMS**
Carrying YOUR Loads



Drive-in Pallet Racking



The Drive-in Racking System is a system in which the same pallets are stored on top of each other and back-to-back with a stacking device in depth with minimum spacing. In this system, the storage vehicles fill the loading channels from the back to the front, using them as a corridor. By entering and exiting the channels with the help of guide rails placed on the floor; pallets are stacked in blocks on specially shaped profiles located in depth in the system.

There are corridor spaces between the units in the system. There are guide rails on the sides for easy and comfortable movement within the corridor. Pallets in the modules are placed on galvanized metal sheets on the right and left on the floors.

- › It offers the opportunity to make maximum use of the warehouse space.
- › A minimum corridor width is needed.
- › It has the flexibility to be produced in different heights and depths.
- › It offers the opportunity to access all materials directly in sequence.
- › It is possible to use multiple tunnels with a single stacking device.
- › You can access your products of the same type with FIFO and LIFO system.

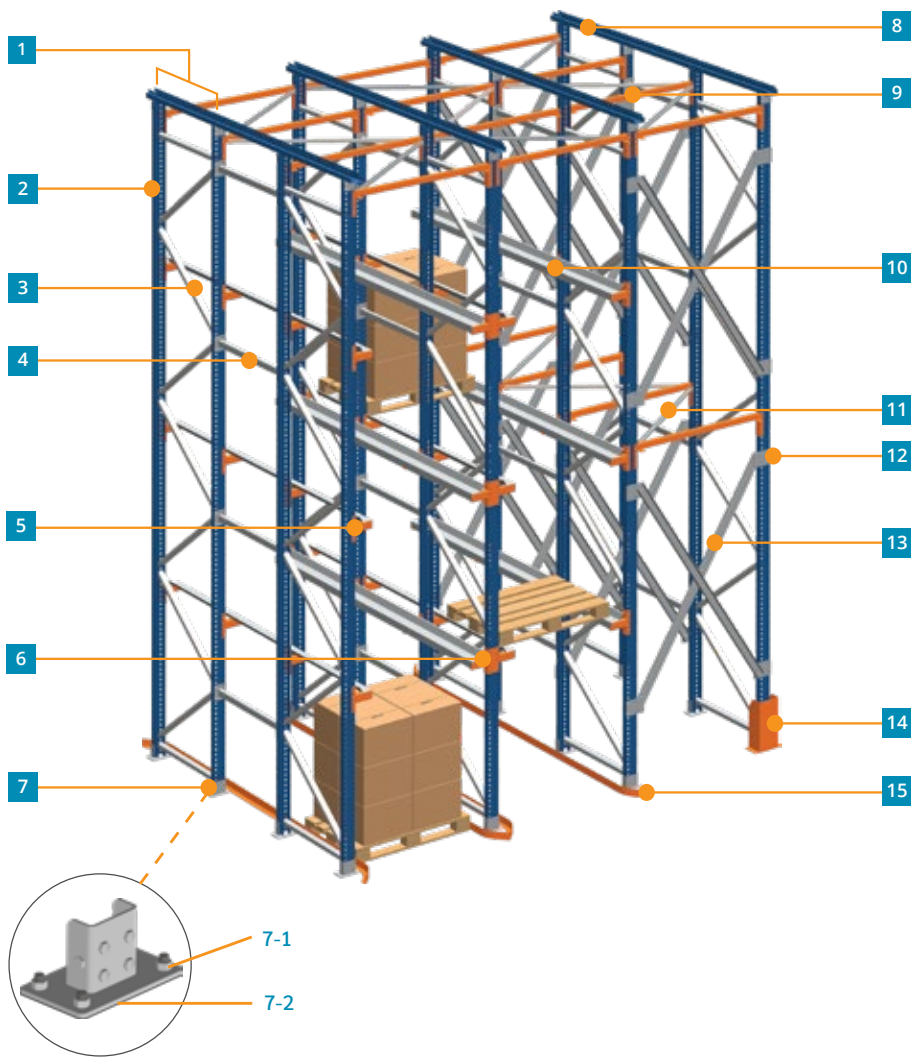

- 1- Frame Set
- 2- Upright
- 3- Frame Diagonal
- 4- Row Spacer
- 5- Rail Support Arm - Single
- 6- Rail Support Arm - Dual
- 7- Base Frame Footplate
- 7-1: Anchor Bolt
- 7-2: Leveling Shims
- 8- Top Connecting Profile
- 9- Beam
- 10- Rail
- 11- Internal Bracing
- 12- Cross Brace Profile Connector
- 13- Cross Brace Profile
- 14- Upright Protector – U Type
- 15- Ground Guide Rail

► FIFO (First In, First Out)

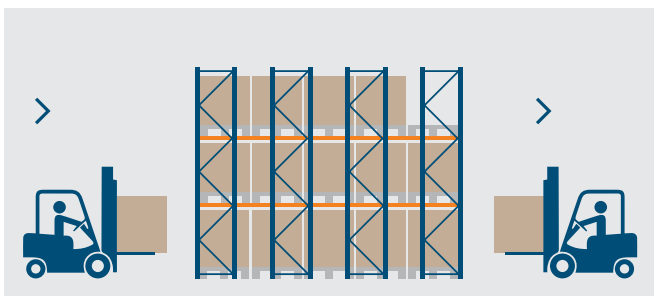

The system operates on a load from one side and unload from the other side principle. It's allowing forklift entry from both directions.

Stock control is applied in warehouse zones managed on a first-in, first-out basis.

► LIFO (Last In, First Out)

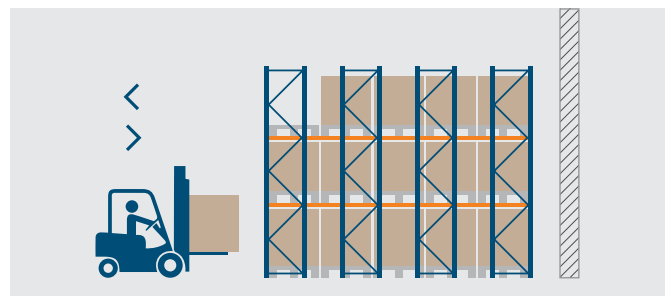

The system, where loading and unloading are done from the same side allows forklift entry from one direction only. Stock control is applied in warehouse zones managed on a last-in, first-out basis. In cases where materials loaded onto a floor need to be unloaded in a single operation, it enables the most efficient use of the warehouse zone.

Narrow Aisle Pallet Racking

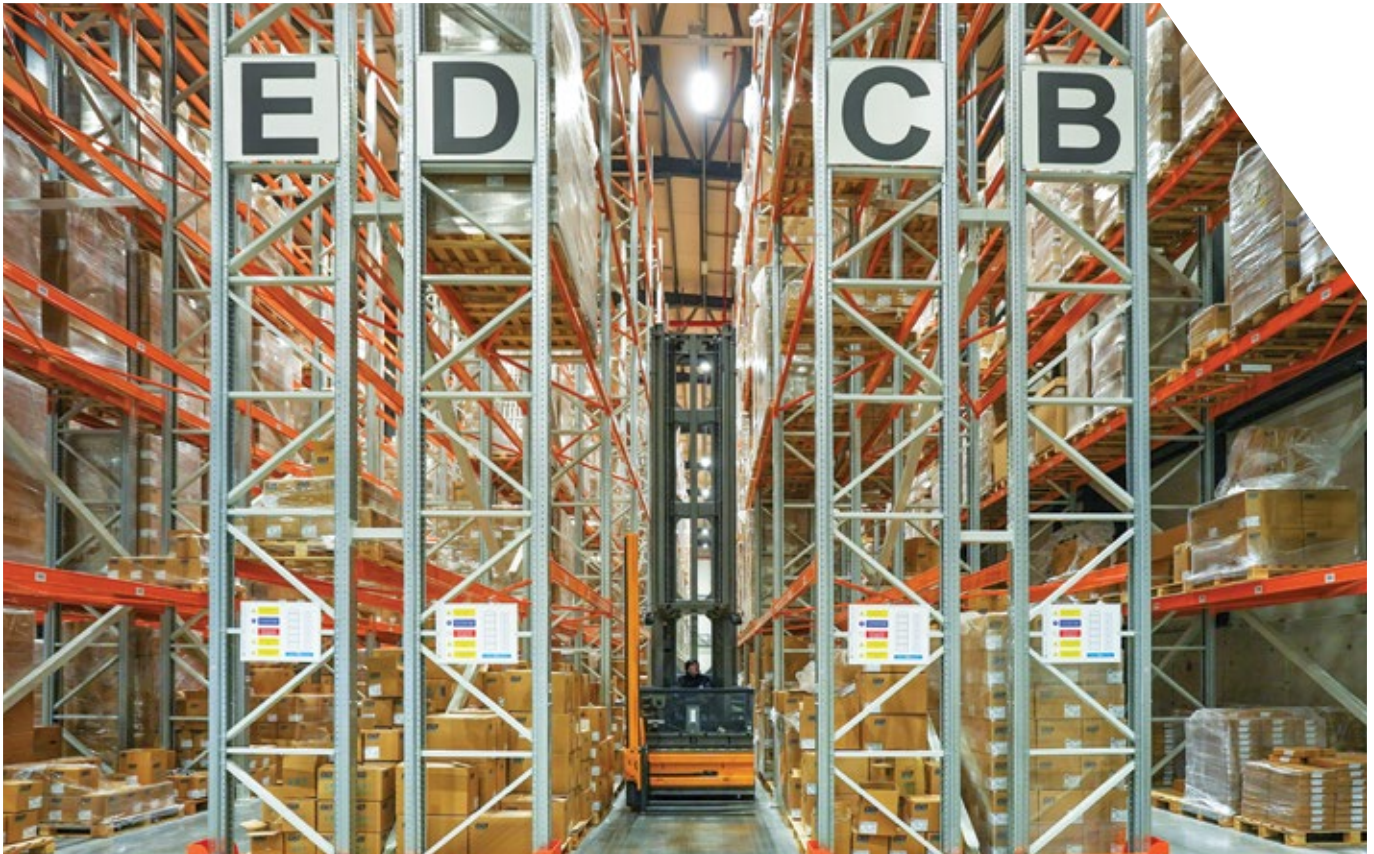

In the Narrow Aisle Pallet Racking with a height of more than 9 meters, the aisle widths are the narrowest since forklifts are used between the aisles. Since forklifts do not need the space required for other stacking vehicles to maneuver, narrow aisles are sufficient in this system. Depending on the characteristics of the forklift used, there may be a need to lay guide rails between the aisles.



- › The distance required by the stacking tools saves space and personnel, as it is narrower than the standard working width.
- › It provides the opportunity to take advantage of the maximum volume (especially the height in high warehouse buildings).
- › It offers quick access to every product.
- › There is a narrower aisle compared to the classical racking system.
- › It also offers the possibility to switch to a fully automatic shelf system upon request.
- › Aisle borders and racking systems are optimized for forklift movements.

Pallet Racking Solutions

Double Deep Pallet Racking



In Double Depth Racking Systems, 2 pallets can be loaded one after the other at the same time. In this way, the storage capacity increases as the aisle area is used less. Due to its deep structure, it is suitable for use with loading vehicles with long forks or fork extension apparatus. Ideal for high storage space.

- › Since products can be placed in two rows at each level of the racks, it increases the storage capacity.
- › Products can be placed on both sides of the racks. This is a common method of storing products, especially with pallets.
- › In a double-depth racking system, access to products is usually provided by a special vehicle (usually forklifts).
- › The double-depth racking system is ideal for businesses that want to achieve high storage capacity, especially in limited spaces.
- › It can be designed to be able to carry heavy loads. It is suitable for pallets with high carrying capacity or large materials.
- › When used in combination with forklifts and other handling equipment, quick access to products and fast loading and unloading operations are possible.



Pallet Racking Solutions

Silo Pallet Racking

In this system, a silo warehouse is created by making a roof and facade coating directly on the rack elements, without the need to build a separate building. In the Silo Pallet Racking, concrete is first poured on the ground and then the rack columns are fixed on this concrete. In the next stage after the constructional steel assembly, the exterior facade and roof are completed by covering with various optional coating materials (panels).

In this system, the shelves not only carry the stacked products but building elements. Different elements of the building and moving stacking vehicles are planned and constructed in such a way as to resist the dynamic effect caused by wind and snow, seismic movements such as earthquakes, and problems caused by all other external factors.

- › Eliminates construction investment costs.
- › It is more economical compared to conventional buildings and racks.
- › It offers savings of up to 35% in construction costs.
- › It prevents space losses caused by columns and beams in buildings.
- › Since it can be built any desired height of up to 30 meters, it provides great savings in land use.
- › Since it is disassembled, it can be dismantled and reassembled elsewhere if desired.

Pallet Racking Solutions

Pallet Flow Racking



- › It offers fast and economical shipment.
- › It provides easy product addressing.
- › It is widely used in the food, pharmaceutical, automotive sectors.
- › It can be equipped with braking systems and safety barriers.
- › It ensures the safe storage of palletized products.
- › Loading is done from one side and unloading is done from the other side, thus speeding up the process.

Pallet Flow Racking is used especially in projects where products that require shipment according to the production date are stored. It is suitable for workplaces that are prone to work according to FIFO principles where products are shipped in pallet and box flow. In this racking system, packages can be loaded on the sloping and roller sliding platforms on the one hand and unloaded on the other hand.

Pallet Flow Racking is the most ideal system used on the edges of order collection and assembly lines. If the conveyors are integrated in front of the system, order and product collection can be faster.





Pallet Racking Solutions

GORILLA Smart Solutions Pallet Shuttle Racking



Peritus's Gorilla Smart Solutions Shuttle Racking System brings speed, flexibility, and maximum operational efficiency to storage processes. Adapting to different warehouse needs thanks to 2-way and 4-way shuttle options, the system fully optimizes product flow in high-density storage areas.

Thanks to the rail system integrated into each level of the racking block, multiple shuttle units can operate simultaneously on different levels; thus, product picking and transportation processes are carried out seamlessly and at high speed. Gorilla shuttle units automatically pick up pallets from their level, transfer them to the elevator

system, and seamlessly proceed to the next task cycle within the storage area. Loads are safely and quickly lowered to ground level using the integrated elevator system.

Equipped with intelligent transfer technology, the shuttle units can automatically move between levels using the elevator system, maximizing the continuity of warehouse operations. As a result, it offers a powerful solution for modern intralogistics processes with higher storage capacity, shorter operation times, and minimal human intervention.

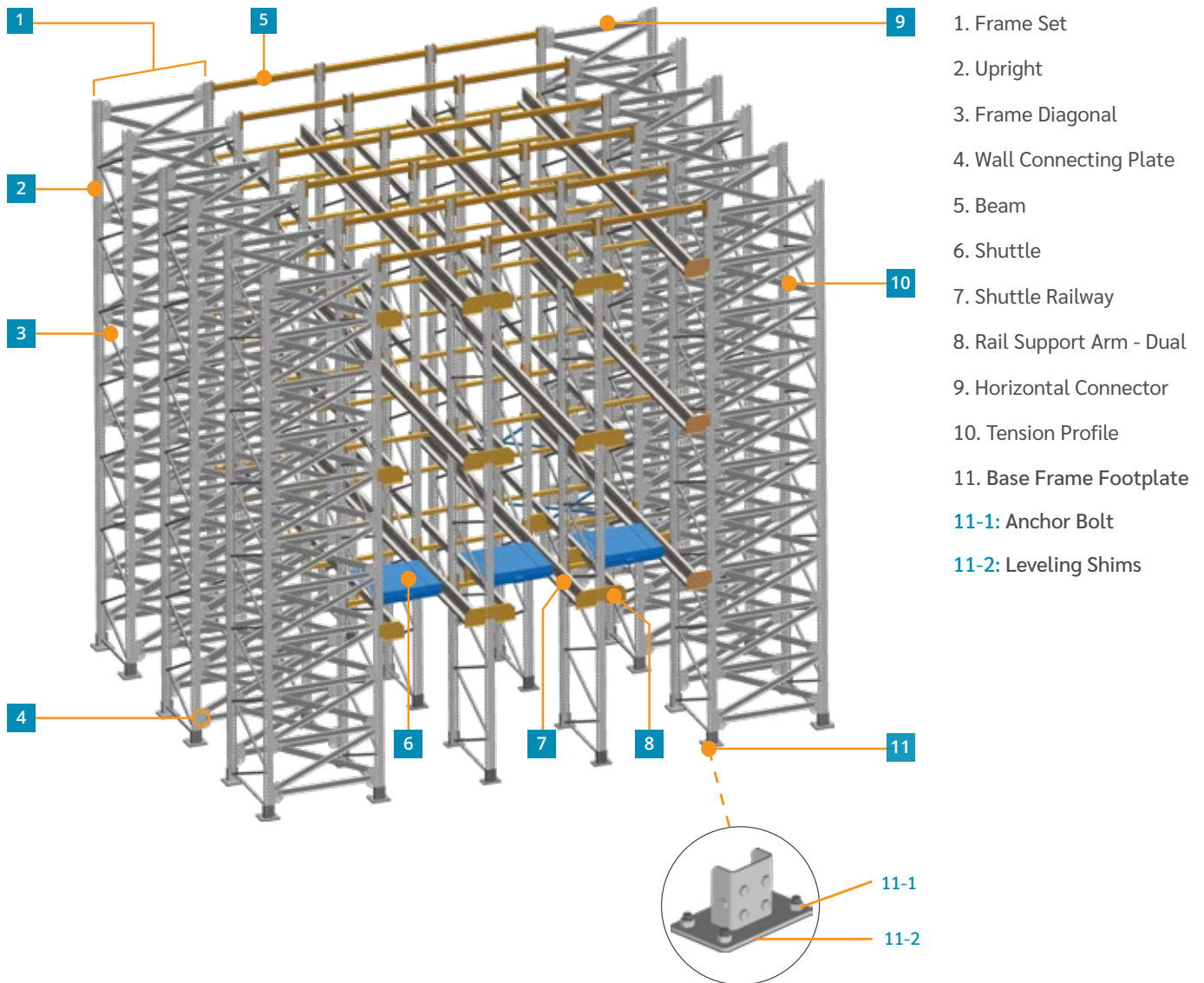

► **FIFO (First In, First Out)**

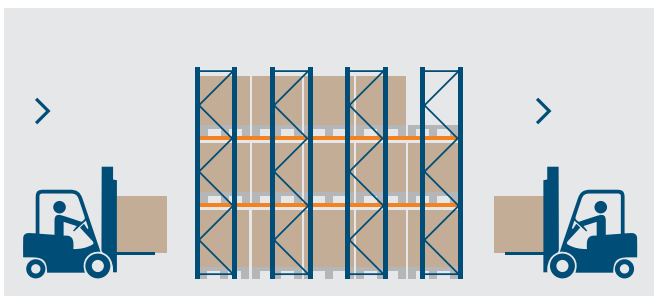

The system operates on a load from one side and unload from the other side principle. It's allowing forklift entry from both directions.

Stock control is applied in warehouse zones managed on a first-in, first-out basis.

► **LIFO (Last In, First Out)**

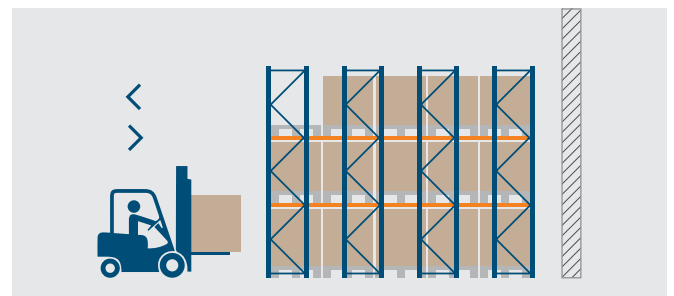

The system, where loading and unloading are done from the same side allows forklift entry from one direction only. Stock control is applied in warehouse zones managed on a last-in, first-out basis. In cases where materials loaded onto a floor need to be unloaded in a single operation, it enables the most efficient use of the warehouse zone.



Pallet Racking Solutions

Mobile Pallet Racking

Mobile racking systems are placed on movable bases that move sideways between static shelving units, thus eliminating the need for aisles in the system. Only one aisle is needed in the system and this aisle is opened only when required for operation. The operator gives the opening command via a remote control or manually by pressing a button on the shelves.

The moving base section consists of motors, motion elements, electronics and various safety systems that guarantee safe and efficient operation.

- › It requires fewer aisles than fixed racking systems, thus increasing warehouse capacity.
- › It is suitable for safe storage of heavy loads and palletized products.
- › The shelves can be moved manually or by remote control.
- › It can be expanded and designed in different sizes according to the needs.
- › It can be equipped with anti-collision sensors, emergency stop buttons and safety barriers.
- › It operates with low energy consumption and reduces operational costs.

Pallet Racking Solutions

AS/RS Pallet Racking



The AS / RS Automatic Storage System, which enables the automatic stacking and retrieval of pallets in high-bay warehouses, has a multifunctional system.

The AS / RS System, which is the weighted choice of companies in locations where renting is costly, ensures that not only the horizontal but also the vertical volume of storage is used in the most efficient way. In this way, the amount of stored product is also be increased. In warehouses with fast circulation; it meets the needs of faultless and fast inventory control, operation and just-in-time ordering.

- › Logistics increases efficiency.
- › Provides automation of warehouse entry and exit operations.
- › It saves labor with its fast and effective operation technique.
- › Reduces storage costs.
- › It provides stock control by ensuring that the products entering and leaving the system can be easily tracked.
- › It eliminates the construction requirements in warehouses, by being easily integrated into existing racking systems.



A-03

A-04

A-05

A-06

A-07

A-08

A-04

Light Duty Shelving Systems

Sliding Shelving System



It is a system designed for light loads, in which the elements are mounted by driving into each other without the use of a bolted connection. The fact that it is a plug-in system provides ease of assembly and disassembly.

It is mainly used in the automotive spare parts sector, as well as in all sectors that need to store their products in the same place and in different ways. It is ideal for storing small sized and high quantity products.

Shelves used in this system can be arranged as glass shelf, long flexible parts shelf, bodywork shelf, shock absorber shelf, bumper shelf, exhaust shelf or door cover shelf, etc. In addition, they are economical and flexible applications.

- › A wide variety of small products can be stored.
- › It can be produced as multiple layers.
- › Efficient use of warehouse volume.
- › Can be used for boxes of any size.
- › Provides ease in product placement and collection.
- › It has the flexibility to be produced in different sizes.

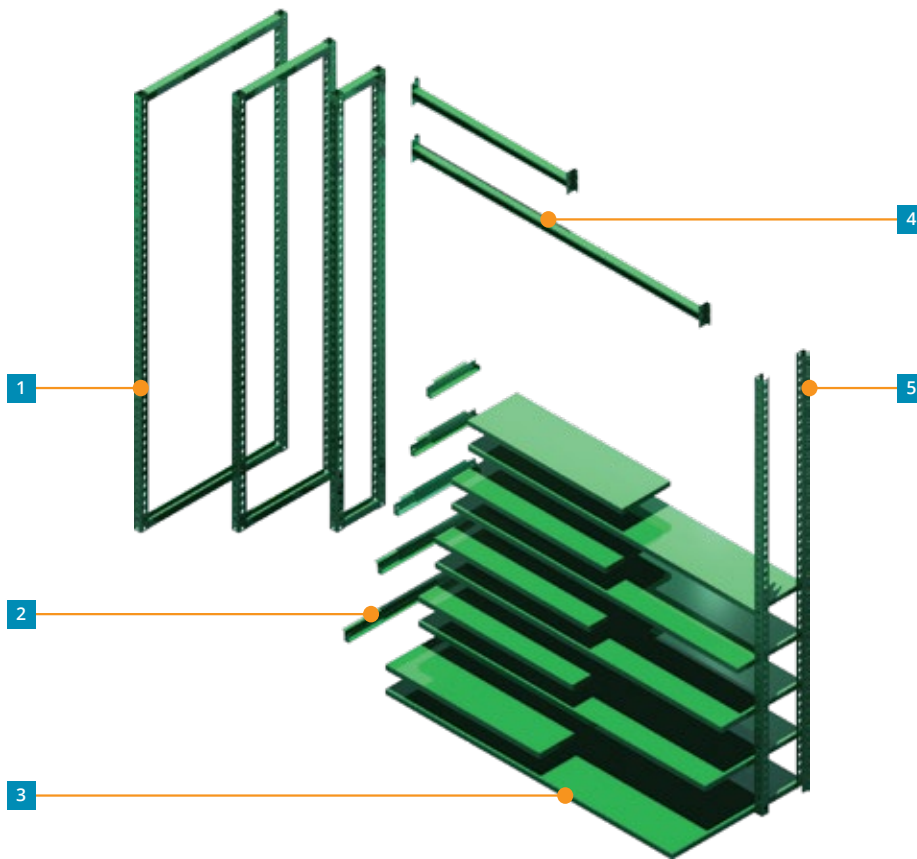

- 1- Frame Set
- 2- Shelf Carrier
- 3- Shelf
- 4- Beam
- 5- Upright

► Endless Applications with Functional Elements

Upright

	H mm	S mm
	1985	1,5 / 2
	2210	
	2300	
	2435	
	2795	
	2975	

Shelf Carrier

	W mm	S mm
	300	2
	450	
	600	
	750	
	900	
	1200	
1500		

Frame Set

	H mm	S mm	W mm
	1985	1,5 / 2	300,450 600,750 900,1200 1500
	2210		
	2300		
	2435		
	2795		
	2975		

Beam

	L mm
	1000
	1800

Shelf

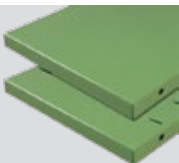
	L mm	W mm	S mm
	250	1000	1 / 1,2
	250	1800	
	300	1000	
	300	1800	
	450	1000	
	450	1800	

Separator Partition

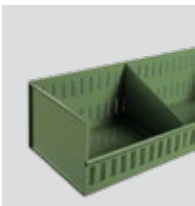
	W mm	L mm
	300	1000
	300	1800
	450	1000
	450	1800
	600	1000
	600	1800
	750	1000
750	1800	

Middle Shelving System



In the Middle Shelving System, manual stocking can be done without the need for a stacking device (forklift). It is ideal for storage of products that are stacked without pallets and in different sizes during the order preparation phase.

It is suitable for companies that need practical order preparation such as supermarkets, electronic goods or spare parts manufacturers and sellers and logistics companies.

- › It accelerates order preparation.
- › Ideal for light to medium weight products.
- › Multiple layer system can be produced.
- › Suitable for automation of boxed products.
- › Modules can be added upon request.
- › It provides high efficiency in storage of medium-sized loads.

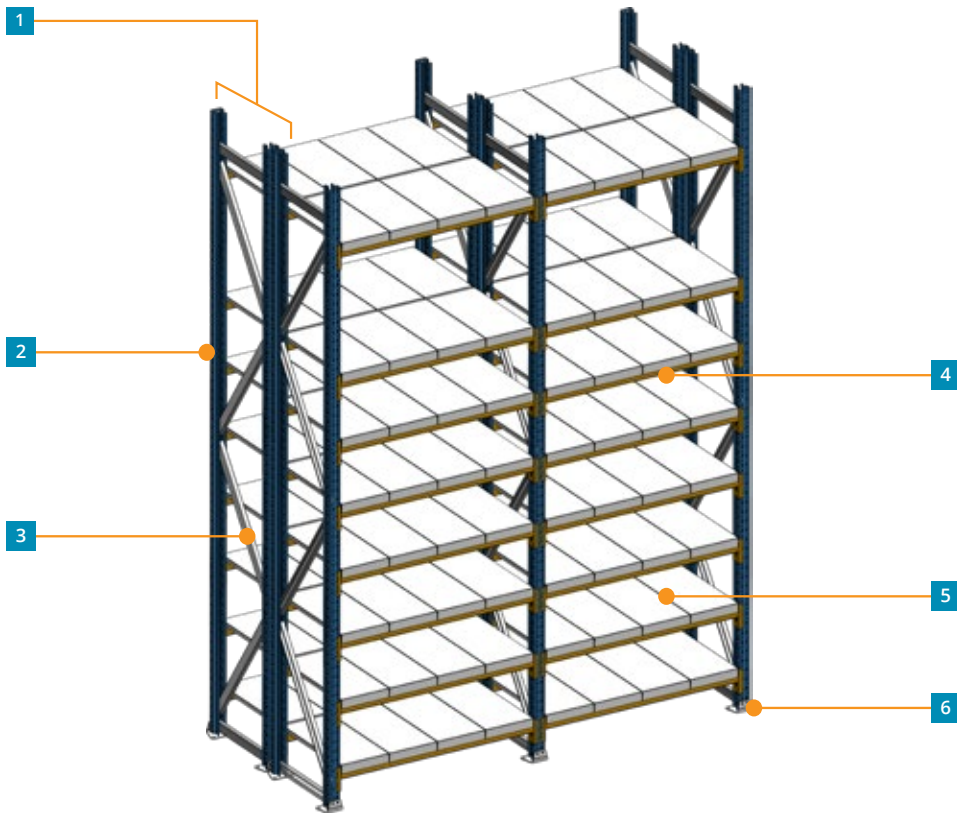

Rax Type Shelving System

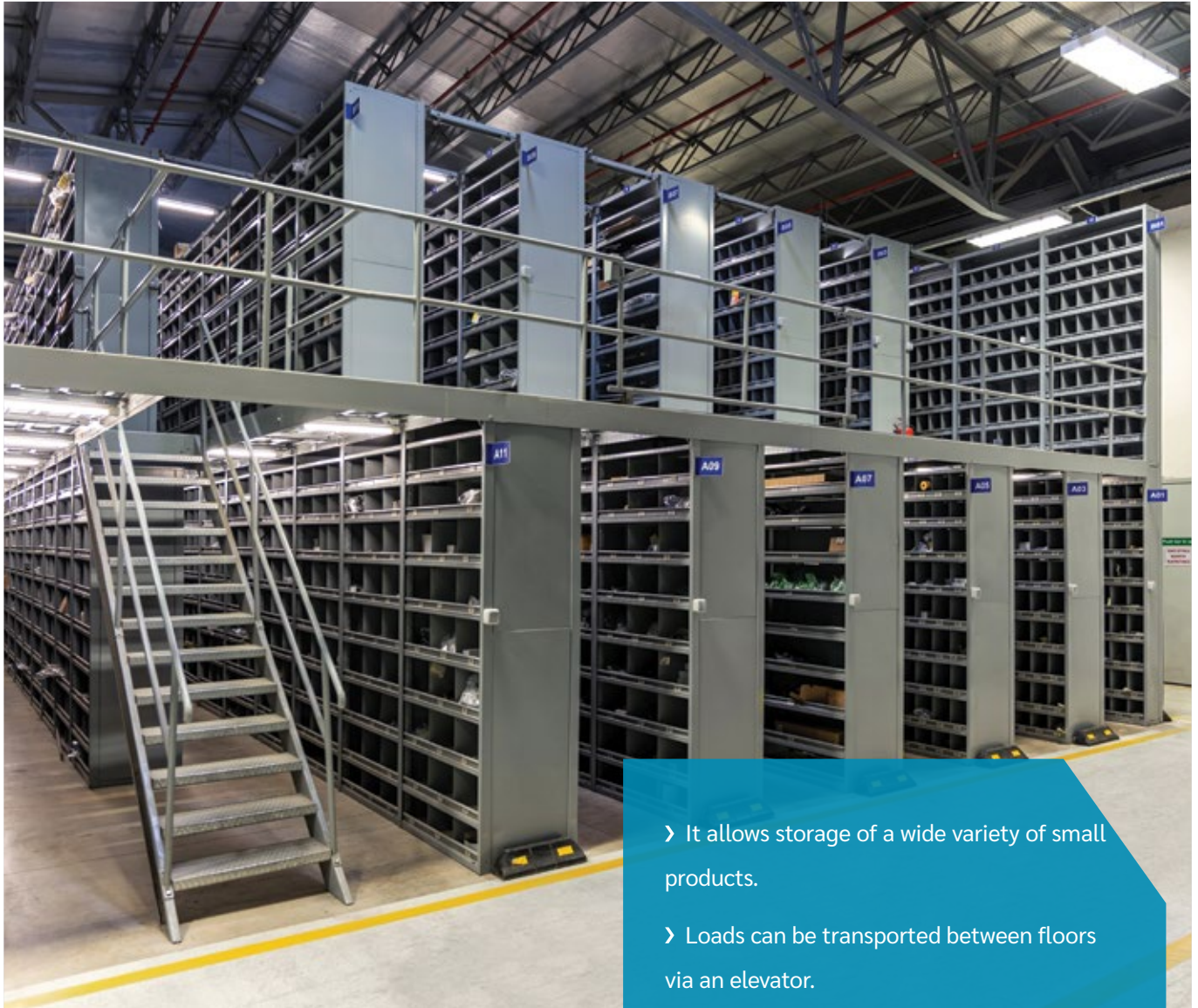

It is a racking system that can be used in all sectors especially in automotive spare parts warehouses where different products need to be stocked in a single area and in different positions.

It is created with a completely modular plug-in assembly that does not use bolted connections.

- › It allows storage of a wide variety of small products.
- › Loads can be transported between floors via an elevator.
- › Depending on the product type, it offers flexibility in height and depth.
- › Product shelf sizes can be changed and the shelves can be divided into their own.
- › Optional modules can be added and removed.
- › It provides easy access to the products with addressing.

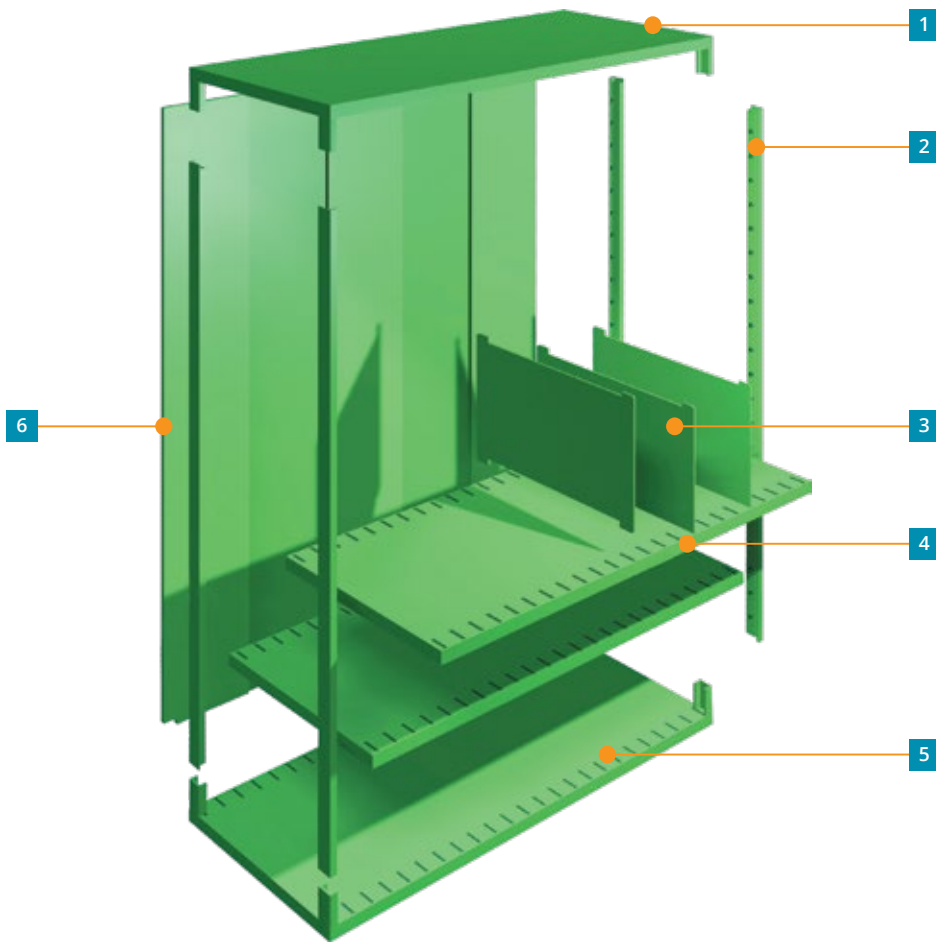

- 1- Upper Shelf
- 2- Frame
- 3- Separator
- 4- Middle Shelf
- 5- Lower Shelf
- 6- Back Sheet





Light Duty Shelving Systems

Hanger Type Racking System

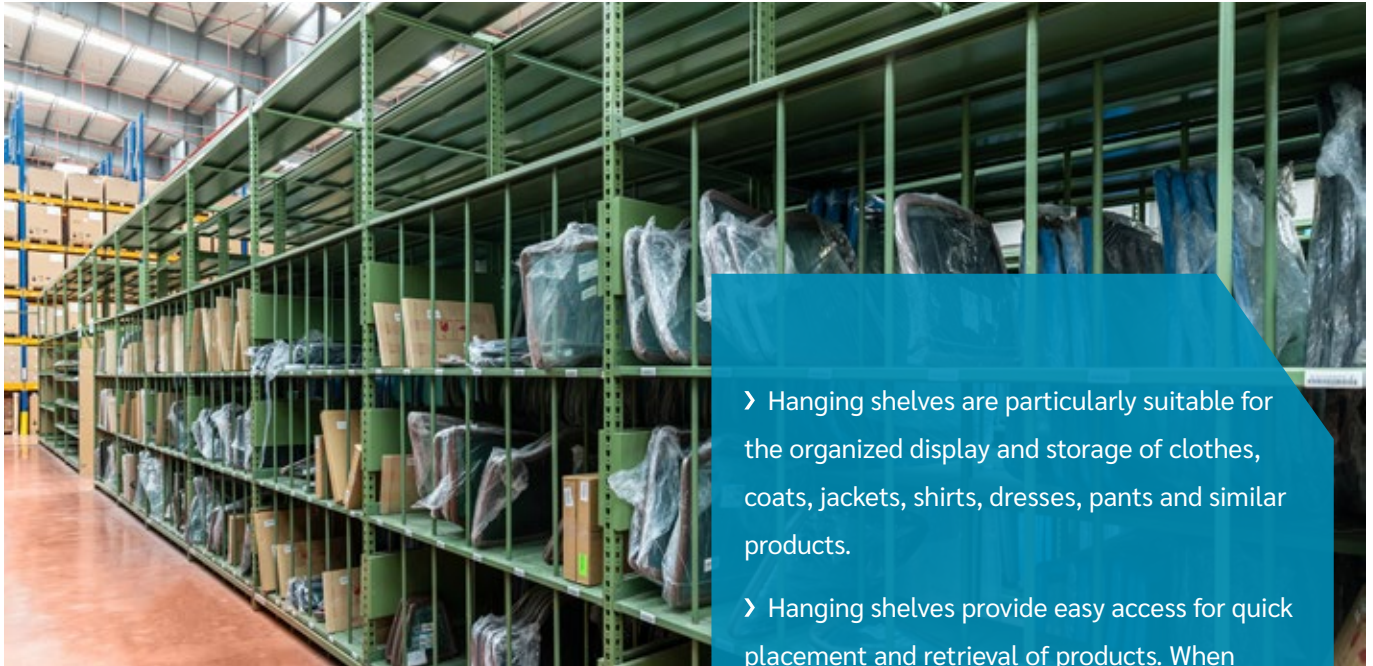

It is a racking system used especially for storing textiles, clothes and similar products that require hangers. In this system, products are usually hung on hangers and displayed in an organized manner. Hanging racking systems are widely used in retail stores, warehouses, textile workshops and clothing production facilities.



› Hanging shelves are particularly suitable for the organized display and storage of clothes, coats, jackets, shirts, dresses, pants and similar products.

› Hanging shelves provide easy access for quick placement and retrieval of products. When products are hung on hangers, each one is easily accessible.

› Hanging shelving systems are usually modular and can be expanded or contracted as required. This ensures that the shelving can be easily adapted to the warehouse or store space.

› Hanging shelving systems are usually made of durable materials. Steel, aluminum or strong plastic materials ensure long-lasting and safe use.

› Hanging shelving systems can be compatible with various types of hangers. Hangers made of different materials such as metal hangers, plastic hangers, wooden hangers can be used.

› In retail stores, hanging shelves allow products to be displayed in an organized and aesthetic way.



Other Storage Solutions

Mezzanine Racking System

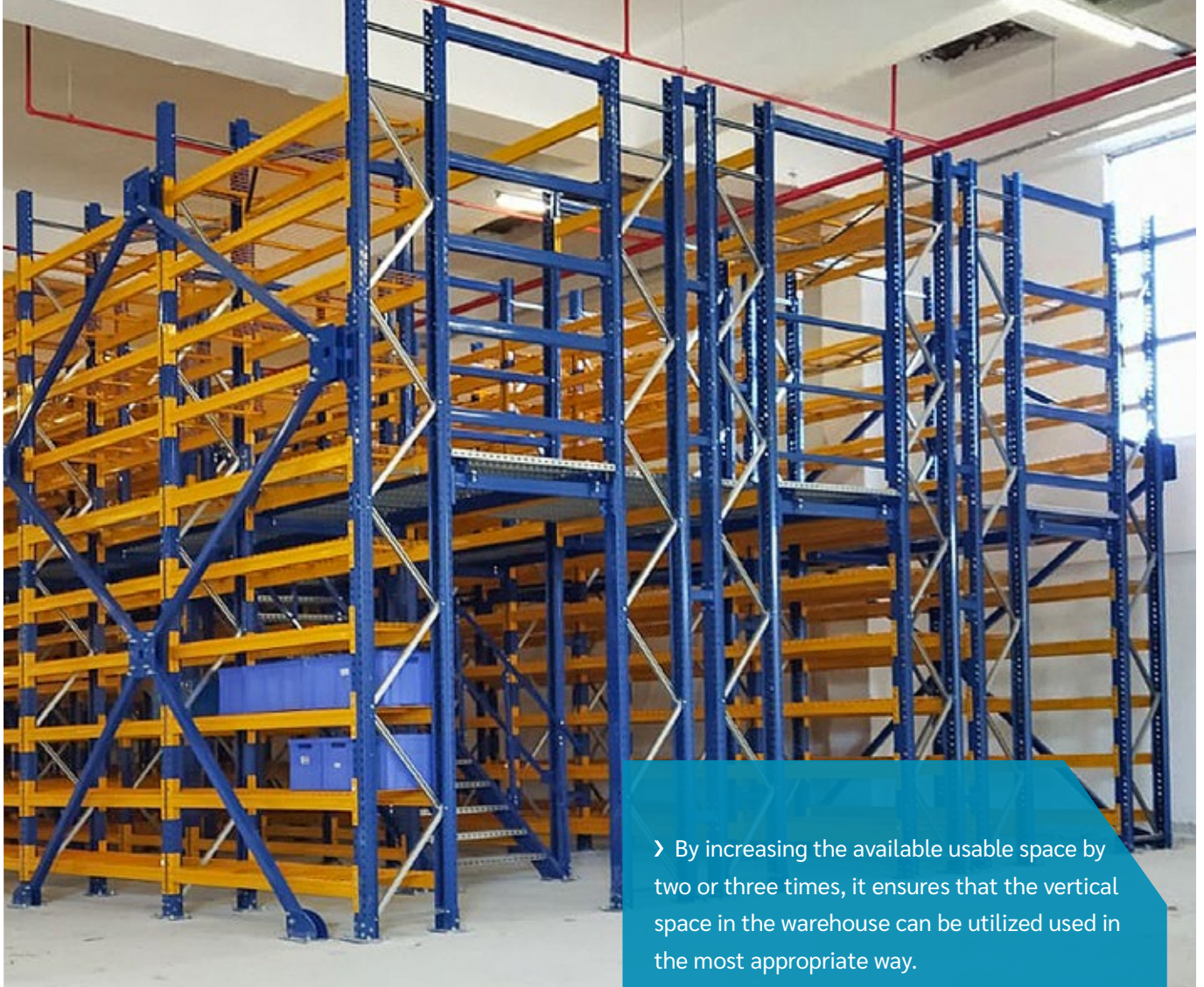

The System, which optimizes vertical space utilization by increasing the available storage space, provides access to all products without using equipment.

The system to which a freight elevator can be added, enables faster and healthier stock material management. It is a modular racking system consisting of two or more layers, designed to make the most efficient use of vertical space in warehouse or production areas.

In this system, an additional platform or floor is created at the top of the racks to optimize the floor space, thereby more storage space is provided.

› By increasing the available usable space by two or three times, it ensures that the vertical space in the warehouse can be utilized used in the most appropriate way.

› It offers the most convenient storage method without the need to expand the building or construct a new building.

› Installation is fast, clean and healthy.

› It creates additional floor space to existing buildings.

› Walkways, lighting, ventilation and fire safety are available.

› The platform surrounded by a guard railing creates a safe space for storage, retrieval and walking in terms of occupational safety.

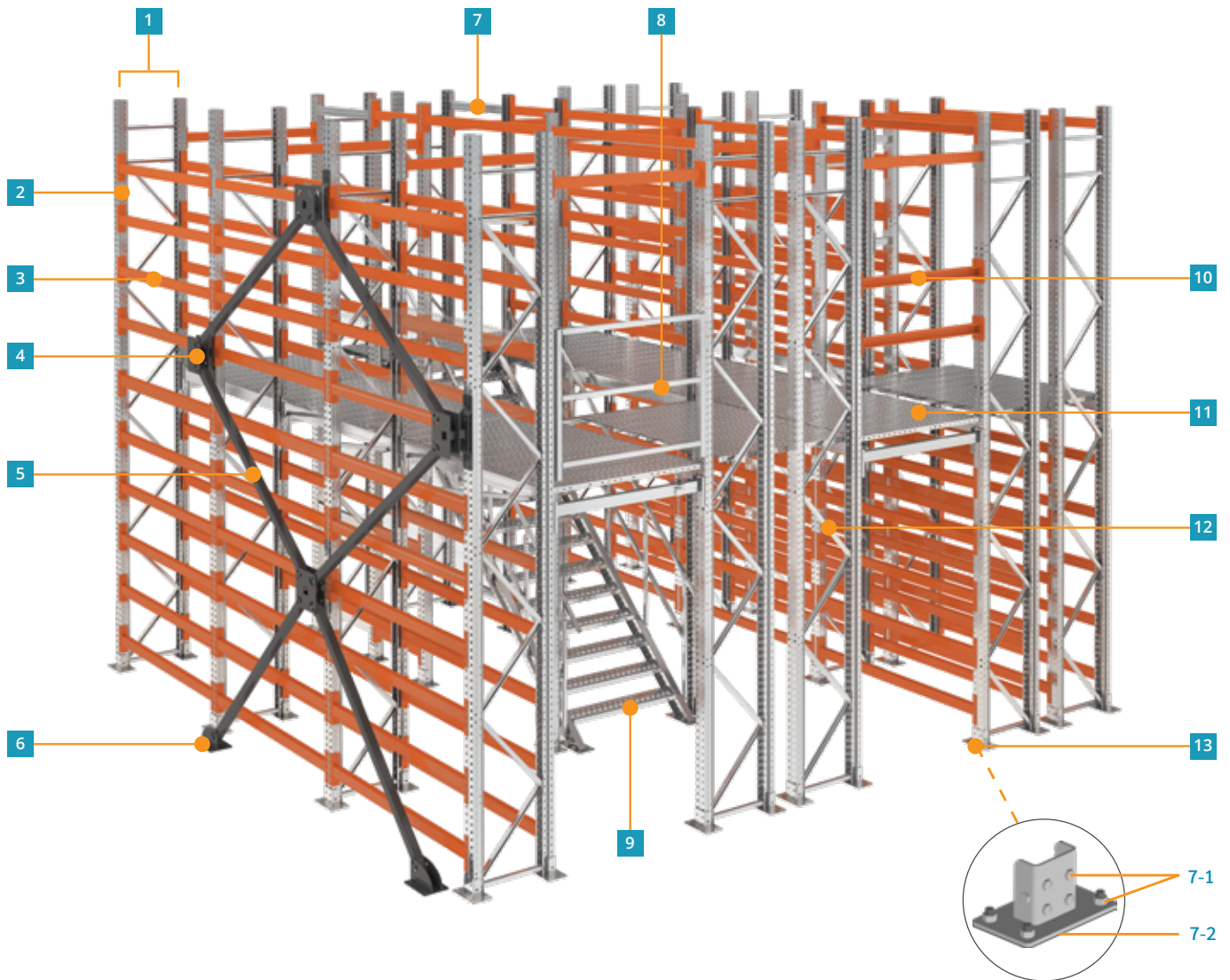

- 1- Frame set
- 2- Upright
- 3- Beam
- 4- Side Stability Profile Connector
- 5- Cross Brace Profile
- 6- Cross Brace Profile Base Connector
- 7- Top Connector
- 8- Pallet Entrance Door
- 9- Stair
- 10- Safety Beam
- 11- Grating / Metal Floor Plate
- 12- Frame Diagonal
- 13- Base Frame Footplate
- 13-1:** Anchor Bolt
- 13-2:** Leveling Shims



PERITUS



Cantilever Racking System

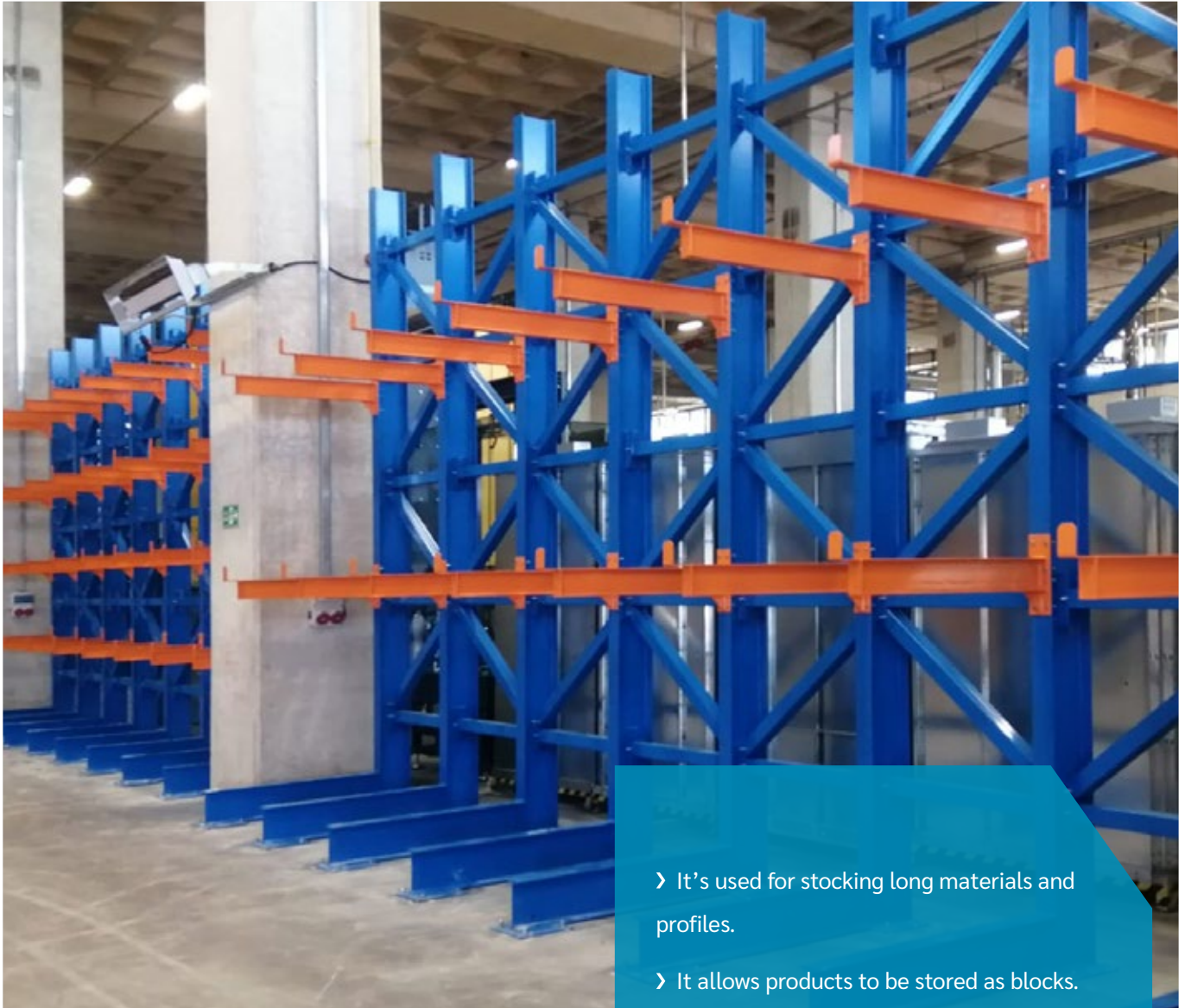

It is used for stocking long-sized and heavy products such as pipes, profiles, boxes. It can be designed as single or double arm according to the intended use. Length and shelf spacing can be adjusted according to the need. It is made of steel or rolled profile according to the weight of the products to be stacked.

- › It's used for stocking long materials and profiles.
- › It allows products to be stored as blocks.
- › Comfortable and unlimited shelf width is available.
- › Floor height adjustment may vary depending on the need.
- › It offers easy access to every product.
- › Cantilever Racking has a modular structure. This makes it possible to expand or contract the system according to needs.

Our Certificates

We have international certifications in our design, project planning, production, sales, and installation processes.





Our References



HE HATKO
ELECTRONICS®

getir
bi mutluluk

dilek
grup

Yelken
Süt ve Sür Ürünleri

LC WAIKIKI

LUFIAN

OLGAR

antik danteL

ÖZLER

B BERICAP

Castrol

Coko

SLT TOŞ

NTG
PLASTİK

hobim
Bilgi İşlem Hizmetleri A.Ş.

INDEX
Türkiye'nin Bilgiye Kaynağı

AKGS
YAPI - DANIŞMANLIK

SANICA

GPD

HÜPPE
SHOWER AND SOUL

FUPALIFT

TÜPRAG
KIŞLADAG ALTIY MADENİ

TÜMAD
MADENLİK, SANAYİ VE TİCARET A.Ş.

anagold
MADENLİK

GÜBRETAS

DRT
DOKTOR YATIRIM

bilim
İLAC A.Ş.
www.bilimilac.com.tr

ABDİBRAHİM

AVOX
pharma

ORVA

SOLGAR®
Since 1947

sora cosmetics



PERITUS

Racking Solutions

📍 Akcaburgaz Mah. Ahmet Yesevi Cad. No:15 Esenyurt, Istanbul, TURKIYE
PERITUS RACKING GMBH - Hohenzollernring 57 - 50672 Köln, Germany

☎ +90 212 886 61 72 - 73
🌐 www.peritusracking.com
✉ info@peritusracking.com

Since **1977**